



EasyF 8W Splitter with UAP 5...2400 MHz 14/16 dB

8-way Splitter with UAP for SMATV signals, using a compact design and an efficient electrical behaviour.

The UAP (User Access Point) provides an additional input for the second downcomer, as specified by ICT-2 regulation concerning installations.

Conceived for indoor installation, it can also be used outdoors with a case (ref. 4163).

Supplied in 10-unit boxes.

Ref.	5433
EAN13	8424450119013

Packaging info

Box	6 pcs.
Bucket	120 pcs.

Physical data

Net weight	239.00 g
Gross weight	258.00 g
Width	121.00 mm
Height	59.00 mm
Depth	15.00 mm
Main product weight	239.00 g

Highlights

- EasyF connection system: easy to install, savings on mounting

- Made of Zamak, high shielding
- Outstanding reliability: automated manufacturing using new generation micro-components

Main features

- Improves through losses
- Outstanding electrical behaviour: impulsive noise reduction
- Grounding screw provided
- DC pass from the outputs to the input

Discover

EasyF connection system: simplicity and savings

EasyF is an innovative connection concept where the inner conductor of the coaxial cable is directly inserted in the device, thus improving connection reliability. Thanks to the absence of F connectors, the chassis can be reduced and the connection of two cables secured with a single screw.

- Real time savings: speeding the installation is possible without the need for coaxial cable termination. Furthermore, there is no need for screwing the connectors on the device, which is sometimes difficult when there is little room
- Connection reliability: the clamp holding the cables prevents the coaxial cable to come off
- Cost savings: no additional connectors are required (neither F nor IEC)
- Space optimization: inputs and outputs are always on the same side of the device to prevent coaxial cables from bending, and to make working inside cabinets and register boxes easier
- Very easy three-step mounting: only screwing and unscrewing the covers is required to connect both cables:

1. Unscrew the device's cover to access the connection

2. Insert the previously stripped coaxial cables

3. Close the cover and screw to ensure connection

Learn more about EasyF system reliability

With EasyF, the connection between the coaxial cable and the device is carried out using an automated system for contact insertion of the inner conductor, without any soldering.

- Always as new: the device's operating life increases when the factor of solder wearing out with time is removed
- Failure rate reduction: usually produced as a result of cold soldering joints
- Electromagnetic behaviour optimization: for high frequencies
- Our commitment with environment is reinforced: pollution caused by the welding process is eliminated and production power consumption is reduced

Application example

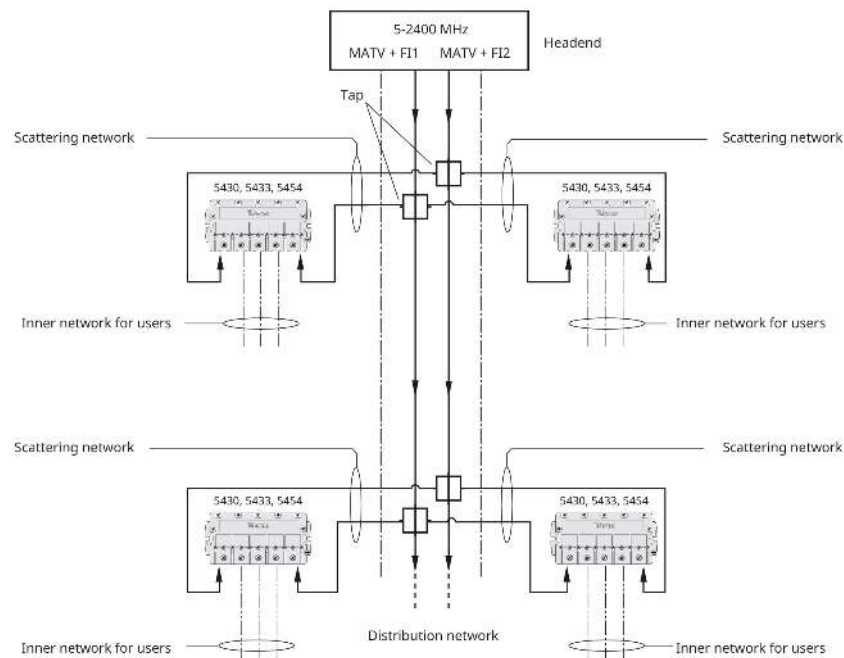

Technical specifications : Ref. 5433

Frequency range	MHz	5 ... 2400	
Number of outputs		8	
Inputs/Bands		TERR	SAT
##	dB	14	14
Through losses W2	dB	14	14
Through losses W3	dB	16	16
Through losses W4	dB	16	16
Through losses W5	dB	14	13
Through losses W6	dB	14	13
Through losses W7	dB	15	14
Through losses W8	dB	15	14
Rejection between outputs	dB	> 28	> 28
Connectors		"EasyF" type	
Voltage max.	V	40	
Max. current	mA	300	
DC pass		OutIn	