



CIES Luminaire N-Series 12LED 39W

Ecological lights made of technical polymer invulnerable everywhere

CIES is the first series of luminaires made of technical polymers specially designed by Televes, combining design, mechanical engineering and the latest electronic technology. These luminaires have a unique style that is also customisable! You can choose from a large number of alternatives: different casing colours, wide colour temperature range, different optics options, and much more.

CIES is an eco-friendly lighting option, from its production from 100% recyclable materials, in a process that minimises the carbon footprint, to its high energy efficiency and durability, which reduces waste generation. What's more, the materials are very light and at the same time resistant, which optimises all the transport, installation and maintenance tasks that are naturally linked to a public luminaire.

Thanks to this range of luminaires, an innovative and ideal solution is provided for the most aggressive environments, especially for maritime and seaside areas.

The N series offers maximum flexibility by adding dimming connectors under ANSI C136.41 NEMA standard, which allows a plug&play connection to remote management nodes and thus provides the ability to connect to IoT infrastructures.

Furthermore, this open interface allows the N Series to be connected to any remote management system, combining the possibilities of full integration with additional sensorisation. Thus, our

luminaires can be perfectly integrated into any Smart City project

Ref.	60080000
EAN13	8424450306567

Other features

Number of LEDs	12
Lighting control	Remote control
Power	39.00 W

Packaging info

Box	1 pcs.
-----	--------

Physical data

Net weight	4,366.00 g
Gross weight	5,566.00 g
Width	263.00 mm
Height	249.00 mm
Depth	504.00 mm
Main product weight	4,366.00 g

Highlights

- **Resistant in any environment:** made of corrosion-resistant materials, self-formulated technical polymers and stainless steel
- **Maximum safety:** technical polymer casing (non-conductive material) and automatic electrical disconnection on opening. Class II and SELV
- **Easy installation and maintenance:** light weight and handy format with tool-free opening and locking of the top cover. Quick on-site replacement of all components
- **Eco-friendly luminaire:** produced from 100% recyclable materials, in a manufacturing process that minimises the carbon footprint. Thanks to this and to its high operating efficiency, CIES helps to preserve the environment and respect for ecology
- **Supports the quality of the night sky:** in accordance with the IAC (Instituto de Astrofísica de Canarias) requirements, the luminaire is suitable for areas of special protection from light pollution (flux emission to the upper hemisphere < 0.1%)

- **100% made in Televes:** technology designed and manufactured in our cutting-edge facilities, guaranteeing total control, with demanding quality monitoring, over each of the production phases

Discover

Our ranges of luminaires encompass a wide range of powers and number of LEDs, in addition to being customizable in the types of lighting control, colour temperatures, optics and their light distribution, and finishes. **A product can be configured according to these parameters, and ordered by its numerical or logical reference**, as follows:

Selecting the luminaire by the numerical reference:

This is a numerical code made up of 14 digits:

- The first 6 digits represent a code that depends on the Series of the luminaire, the number of LEDs and the power
- The next 8 digits allow you to choose the configurable parameters of the luminaire: lighting control, colour temperature, type of optics and finish

Series		Dimming		Colour Temperature		Optics		Finish	
631703	<i>Urban Alameda E 24LED 53W</i>	00	<i>No Dimming</i>	18	<i>PC Amber</i>	02	<i>SP</i>	02	<i>Black</i>
631713	<i>Urban Alameda E 24LED 39W</i>	01	<i>Dimming</i>	22	<i>2200K</i>	11	<i>D90</i>	xx	<i>Custom</i>
				27	<i>2700K</i>	17	<i>T2-C90</i>		
				30	<i>3000K</i>	18	<i>T3-B90</i>		
				40	<i>4000K</i>				

Selecting the luminaire by logical reference:

This is an alphanumeric code composed of an unlimited number of characters, describing the luminaire's characteristics using logical abbreviations, to facilitate its interpretation. It is divided into 2 groups of characters, separated by a hyphen:

- The first group specifies: the luminaire series, the number of LEDs, the colour temperature, and the lighting control

- The second group specifies: the type of optics, the finish and the power

An example of a logical reference: UA2418D-D90BL53

- **UA** – *Urban Alameda*
- **24** – *24 LEDs*
- **18** – *Colour Temperature: PC Amber*
- **D** – *Dimming included*

- **D90** – *D90 Optics*
- **BL** – *Black colour*
- **53** – *53W Power*

Range & LED number		Colour Temperature		Dimming		Optics	Finish		Power		
UA24	<i>Urban Alameda E 24LED</i>	18	<i>PC Amber</i>	(ø)	<i>No Dimming</i>	SP	BL	<i>Black</i>	53	<i>53W</i>	
		22	<i>2200K</i>	D	<i>Dimming</i>	D90	xx	<i>Custom</i>	39	<i>39W</i>	
		27	<i>2700K</i>								
		30	<i>3000K</i>								
		40	<i>4000K</i>								

Graphic documentation

ME



cd/klm ■ C0 - C180 ■ C90 - C270 $\eta = 88\%$
Light distribution curve

P



cd/klm ■ C0 - C180 ■ C90 - C270 $\eta = 94\%$
Light distribution curve

T2



cd/klm ■ C0 - C180 ■ C90 - C270 $\eta = 90\%$
Light distribution curve

T3



cd/klm ■ C0 - C180 ■ C90 - C270 $\eta = 92\%$
Light distribution curve

SCL



cd/klm ■ C0 - C180 ■ C90 - C270 $\eta = 86\%$
Light distribution curve

APZ

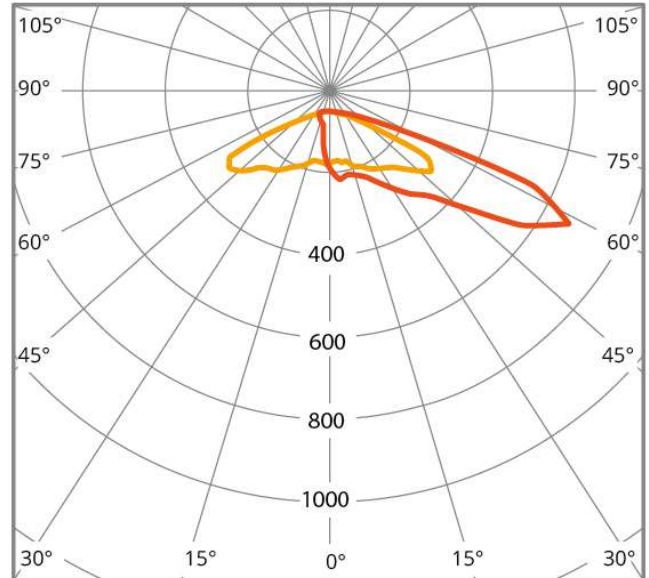

cd/klm ■ C0 - C180 ■ C90 - C270 $\eta = 96\%$
Light distribution curve

T4



cd/klm ■ C0 - C180 ■ C90 - C270 $\eta = 94\%$
Light distribution curve

Features

A luminaire with a unique personality

It combines design, engineering and modernity



CIES features a slightly wavy design, that evokes the ocean tides of the environment surrounding the natural park of the Atlantic Islands of Galicia. Created in a maritime and island environment, CIES is known for its excellent performance in extreme weather conditions.

Its design inspired by the Galician archipelago is manifested in the contrast between the strength and hardness of its materials and the lightness and mellowness of its style, such as the fine sand dunes that harmonise with the robustness of the islands.

Invulnerable in any environment

Designed to last



CIES is made of corrosion-proof materials: technical polymers with a proprietary formula and stainless steel. By avoiding the use of mixed metals, the possibility of galvanic corrosion is completely eliminated, thus ensuring a long life for the luminaire.

Its UV-stabilised technical polymer casing is vandal-resistant, withstanding impacts of IK10 level.

CIES is the ideal luminaire for maritime areas, as it is particularly resistant to exposure to adverse weather conditions with high levels of humidity and/or salinity.

A world of possibilities

Customisable style for every situation

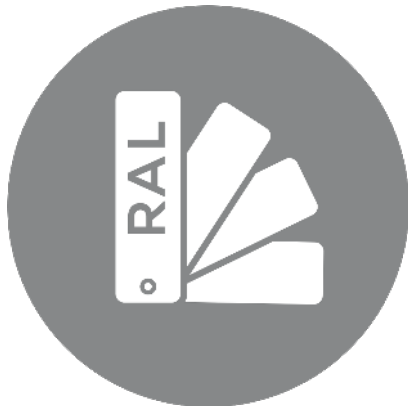

Each situation requires specific lighting features, that's why our luminaires offer multiple alternatives to meet the needs of each context:

- A wide selection of highly homogeneous colour temperatures (SDCM<3): PC Amber, 2,200, 2,700, 3,000 and 4,000°K
- 7 different types of optics are available to achieve lighting adapted to any environment: P, ME, T2, T3, T4, APZ and SCL
- Variety of finishes in any colour of the RAL range
- CRI>70 and available on request CRI>80 and CRI>90

And if you don't find what you are looking for, we have even more options available on request. We are pleased to study your project in a tailored, non-binding way. Contact us, and we will help you choose the perfect lighting.

Perfect thermal management

Materials and design that enhance dissipation

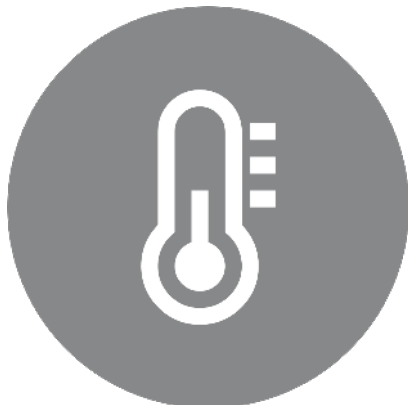

The CIES luminaire has a passive cooling system for the light source. High-quality thermopolymer heat sinks ensure thermal conductivity, resulting in great temperature stability. In addition, the electronics compartment is separated from the LED modules, which prevents heat transfer between the two points. Thanks to the thermal protection of the electronics, the light's lifetime is maximised (L90B10 > 100,000h at 25°C) and its efficiency is greatly improved (up to 160 lm/W).

Easy installation and maintenance

On-site and tool-free replacement



CIES has been designed to simplify installation and maintenance tasks as much as possible. From its light weight and handy format, to its tool-free cover opening and locking system, facilitating on-site replacement of any of its components.

Moreover, the luminaire has a self-cleaning system thanks to the grooves located in the top part of the luminaire, helping to clean and preventing possible degradation due to the accumulation of dirt.

Sustainable and ecological lighting

Supporting the quality of the night sky



Inspired by a protected natural area, CIES supports the preservation of the environment and respects the ecology and quality of the night sky. According to the requirements of the IAC (Instituto de Astrofísica de Canarias), CIES is suitable for areas of special protection against light pollution, with a light emission to the upper hemisphere of less than 0.1%, emitting an adequate luminous flux, directed only towards the areas of interest.

Environmentally friendly under the 3 "R's".

Reduce, re-use and recycle



In order to reduce environmental damage and take care of our planet, we take responsibility to contribute by following the 3 "R" rule:

- Reduce: Our manufacturing process reduces by 50% the carbon footprint generated, compared to aluminium equivalents
- Reuse: The luminaire can live on in the infrastructure, thanks to a LED module and driver replacement in a sustainable way, supporting the circular economy
- Recycle: The luminaire is made of 100% recyclable materials

100% electrical safety

Maximum protection



This luminaire has the best levels of electrical protection: its Class II guarantees safety without the need for ground connection thanks to the double isolation of the components. Furthermore, the SELV certificate guarantees an output voltage of less than 60V, minimising the risk of electrocution in the event of system failure. In addition, its driver, optical group and IP68 connections offer integral protection to all the optical and electronic elements against the ingress of water and dust, eliminating any effect caused by external agents.

Finally, the casing made of technical polymer (non-conductive material) eliminates completely the possibility of electrocution in the event of contact with the luminaire.

Control and connectivity

Range of luminaires with ANSI C136.41 NEMA socket and programmable driver

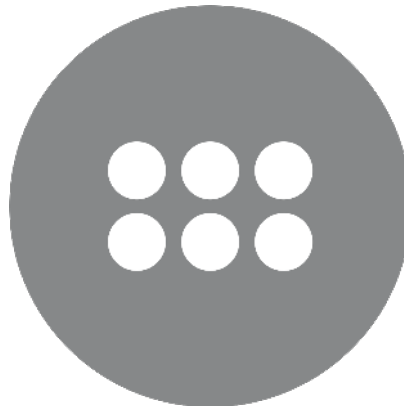

N series incorporates drivers with 1-10V communication protocol, allowing luminous flux regulation between 1 and 100% by varying the voltage of the input signal from 1 to 10V. Luminaires of this series include the ANSI C136.41 NEMA standard socket that allows Plug&Play connection with remote management nodes and the integration of several sensors (presence, twilight, noise, air quality...).

Televes quality guarantee

With over 60 years of European manufacturing experience



Our cutting-edge facilities are equipped with all the means to guarantee a quality and reliable luminaire, highlighting precise traceability and rigorous verification of all processes. This is possible thanks to an advanced methodology of product design under simulation and in-house manufacturing on robotised lines, in collaboration with national and local providers.

Mounting details

Quick and easy mounting by using a single accessory for vertical and horizontal position of great strength and durability, made from a specially-formulated technical polymer.

The rotation of the lighting unit can be adjusted up to 30°. It is also adaptable to posts, columns and arms with Ø 42 to 60 mm, and adapters are available for other diameters.

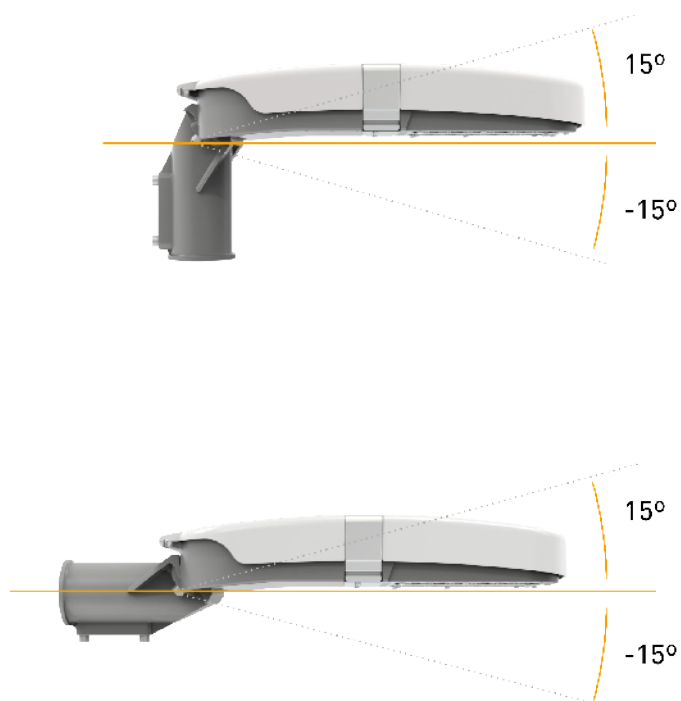

Tool-free top opening for access to electronics and LED module. Electrical disconnection on opening to minimise the risk of electrocution.



